



# IALA GUIDELINE

1098

## THE APPLICATION OF AIS - AtoN ON BUOYS

**Edition 1.0**

**May 2013**



# DOCUMENT REVISION

---

Revisions to this IALA Document are to be noted in the table prior to the issue of a revised document.

Date	Page / Section Revised	Requirement for Revision
May 2013	1 <sup>st</sup> issue	



# CONTENTS

---

<b>1. INTRODUCTION .....</b>	<b>6</b>
<b>2. SELECTION OF THE AIS UNIT .....</b>	<b>6</b>
2.1. AIS-AtoN type .....	6
2.1.1. Type 1 .....	6
2.1.2. Type 2 .....	6
2.1.3. Type 3 .....	6
2.2. Messages .....	6
2.2.1. Message 6.....	7
2.2.2. Message 8.....	7
2.2.3. Message 21 .....	8
2.2.4. Message 25 .....	8
2.2.5. Message 26 .....	8
2.2.6. Message Protocols.....	8
2.2.7. Position fixing devices.....	8
<b>3. PRIMARY CONSIDERATIONS.....</b>	<b>8</b>
3.1. Power consumption.....	8
3.2. Transmission range.....	9
3.2.1. Extraordinary coverage – Ducts or Tropospheric Refraction.....	10
3.2.2. Selection of VHF antenna .....	11
3.2.3. Comparison of different marine antenna .....	11
3.2.4. Redundancy.....	13
3.3. Integrated AIS-AtoN Units .....	13
3.3.1. Integrated unit with other equipment.....	13
3.3.2. Integrated with Lantern and Power system .....	13
3.4. Licensing by local licensing authority.....	13
3.5. Additional services.....	14
3.5.1. Message 8.....	14
3.5.2. Message 21 – AtoN Status - Monitoring capability (battery status, light status, RACON status, etc.) .....	14
3.5.3. Interfacing with existing telemetry systems .....	14
3.5.4. Satellite monitoring of AIS.....	14
<b>4. PHYSICAL APPLICATION .....</b>	<b>14</b>
4.1. Location of VHF antenna and GNSS antenna receivers.....	14
4.1.1. VHF antenna.....	14
4.1.2. GNSS Antenna .....	15
4.1.3. Choice of location for antennae.....	15
4.2. IP rating .....	15
4.2.1. Issues .....	15
4.2.2. IP enclosure rating .....	16
4.2.3. Pressure balance.....	16



# CONTENTS

4.3.	Lightning protection. ....	16
4.3.1.	Grounding.....	16
<b>5.</b>	<b>COMMISSIONING &amp; TESTING .....</b>	<b>16</b>
5.1.	Configuration.....	16
5.2.	Functional tests .....	17
5.2.1.	Equipment.....	17
5.2.2.	Measuring instruments.....	17
5.2.5.	Data, curves, images and graphs - example. ....	18
5.2.6.	Pre-deployment trial.....	21
5.2.7.	Analysis of results .....	21
5.2.8.	Tests pre deployment .....	21
5.2.9.	Tests post deployment .....	21
<b>6.</b>	<b>MAINTENANCE &amp; OPERATION.....</b>	<b>21</b>
6.1.	Maintenance requirements .....	21
6.1.1.	Technical Staff.....	21
6.1.2.	Configuration Software.....	22
6.2.	Training.....	22
6.2.1.	Capabilities required for maintainers .....	22
6.2.2.	Human, physical and technical restrictions on board. ....	22
6.2.3.	Training documentation .....	22
6.3.	Spare transponders .....	22
<b>7.</b>	<b>SELECTION OF EQUIPMENT .....</b>	<b>23</b>
<b>8.</b>	<b>GENERAL CONSIDERATIONS FOR INTEGRATING AN AIS-AtoN SYSTEM.....</b>	<b>23</b>
8.1.	Impact on buoy performance .....	23
8.2.	General Assembly.....	24
8.2.1.	Hard wired and plug connectors.....	24
8.2.2.	Preparation of inlets in watertight enclosures .....	24
8.2.3.	Assembly of cable glands.....	25
8.2.4.	Preparation of the AIS System.....	25
8.2.6.	Connections and Completion .....	26
8.3.	General outlines for the assembly.....	27
<b>9.</b>	<b>ACRONYMS .....</b>	<b>27</b>
<b>10.</b>	<b>REFERENCES .....</b>	<b>28</b>
<b>ANNEX A</b>	<b>SAMPLE CHECKLIST .....</b>	<b>29</b>

## List of Tables

<i>Table 1</i>	<i>Summary of optional AIS AtoN Station messages.....</i>	<i>7</i>
<i>Table 2</i>	<i>Suggested spare transponder holding .....</i>	<i>23</i>



# CONTENTS

---

Table 3	Sample checklist .....	29
---------	------------------------	----

## List of Figures

Figure 1	Cross-section of the geoids .....	9
Figure 2	Normal situation – Reception coverage $\approx$ 35 km .....	10
Figure 3	Situation with ducts – Reception coverage $\approx$ 200 km .....	11
Figure 4	Measurement 1 .....	12
Figure 5	Measurement 2 .....	12
Figure 6	Measurement 3 .....	13
Figure 7	Antenna damage due to collision .....	15
Figure 8	Basic connection between systems for Type 1 .....	17
Figure 9	Measurement of power transmitted via direct connection through cable and signal attenuation. ....	18
Figure 10	Consumption [ $\mu$ A] vs. Samples, samples taken every 12 ms. ....	18
Figure 11	Consumption during transmission [A].....	19
Figure 12	Bench test.....	19
Figure 13	Spectrum analyzer displaying transmission spectrum. ....	20
Figure 14	Trace from spectrum analyser showing transmission frequency 162.025 MHz of the AIS-AtoN output.....	20
Figure 15	Example of a double enclosure .....	24
Figure 16	Different sides of the perforated box.....	25
Figure 17	Equipment with its protection .....	26
Figure 18	Sealing of antenna and power supply inputs. ....	26
Figure 19	Sealed cable gland with heat shrink .....	26

## List of Equations

Equation 1	Height of antenna with respect to the centre of the earth .....	9
Equation 2	Operational range .....	10
Equation 3	Standing Wave Ratio .....	11



## 1. INTRODUCTION

---

This document considers the application of employing AIS-AtoN on buoys and is designed to offer guidance regarding specification, installation and maintenance. This document should be considered as complimentary to higher level documents such as IALA Recommendation A-126 on the use of the AIS in Marine Aids to Navigation Service.

This document also applies to installation of AIS-AtoN on fixed structures open to the elements.

## 2. SELECTION OF THE AIS UNIT

---

AIS has the capability of transmitting various messages. The comprehensive list of messages available is in the IALA Recommendation A-126. The main messages that are of interest to the AIS as an AtoN provider are explained in Chapter 2.2.

### 2.1. AIS-ATON TYPE

---

#### 2.1.1. TYPE 1

This AIS-AtoN Station is a transmit-only station, operating in FATDMA mode. Hence the slots used by the Type 1 AIS-AtoN Station need to be reserved by a competent authority using Message 20, transmitted from an AIS base station in the coverage area. The Type 1 unit must be configured to use the slots reserved for it before being placed into service.

This is the simplest type of AIS-AtoN station, likely to have low cost and low power consumption.

#### 2.1.2. TYPE 2

This AIS-AtoN Station is not in common use but is similar to a Type 1 but has, in addition, an AIS receiver of limited capability which allows the Type 2 Station to be remotely configured via the AIS VDL. This receiver operates on a single AIS channel.

#### 2.1.3. TYPE 3

This AIS-AtoN Station is more complex than the Type 1 and contains two AIS receiving processes that allow it to participate fully on the AIS VDL. This means that in addition to FATDMA, the Type 3 station can function in RATDMA mode.

The Type 3 station is therefore capable of:

- autonomous operation, not requiring slot reservations (RATDMA);
- autonomous operation using slots reserved by a competent authority, using message 20, transmitted from another AIS Station in the coverage area (FATDMA);
- receiving and relaying AIS messages, including control and configuration messages for itself or for other AIS AtoN stations in a chain. See IEC 62320-2 for more details of chaining;
- indirect synchronisation, using its receiving processes;
- generating virtual or synthetic AtoN.

### 2.2. MESSAGES

---

In addition to Aids to Navigation Report, Message 21, an AIS AtoN may also transmit Messages 6, 7, 8, 12, 13, 14, and 25. Note that Type 1 and Type 2 AIS AtoN stations, not having full AIS receiver capability, cannot send Messages 7, 13 or 26.

**Table 1 Summary of optional AIS AtoN Station messages**

<b>Msg ID</b>	<b>Message Name</b>	<b>Message Description</b>	<b>Application examples</b>
6	Binary Addressed Message	Binary data for addressed Communication	Monitoring of AtoN lantern, power supply, etc.
7	Binary acknowledge message	Acknowledge of addressed binary message	
8	Binary Broadcast Message	Binary data for broadcast communication	Meteorological and hydrological data
12	Addressed Safety Related Message	Safety related data for addressed communication	Warn AtoN malfunctioning
13	Safety related acknowledge message	Acknowledge of addressed safety related message	
14	Broadcast Safety Related Message	Safety related data for broadcast communication	Warn AtoN malfunctioning
21	AIS AtoN message		
25	Single slot binary message	Binary data for addressed or broadcast communication	Status report
26	Multiple slot binary message	Using SOTDMA	

### **2.2.1. MESSAGE 6**

Message 6, Addressed Binary Message, can be employed by an AIS AtoN for sending AtoN status reports to the competent authority responsible for the AtoN. Useful data includes those for battery, lantern status, and solar power system charging current. The benefits for the competent authority include knowledge of equipment status, opportunity for preventative maintenance, early notification of faults, and ultimately increased availability. Such performance information can be fed back into the design process for AtoN systems. Refer to IALA Recommendation A-126[1], ANNEX C for examples of Message 6 for AtoN monitoring.

It can also be used for remote control of the AtoN. The content of the message is not standard and can vary between manufacturers.

### **2.2.2. MESSAGE 8**

Message 8 is a binary broadcast message. IMO has published a limited list of Message 8, Application Specific Messages, for international use (SN.1/Circ.289). Competent authorities may use other Message 8 formats on a regional basis.

As an example, among the list of IMO Application Specific Messages is a message for meteorological and hydrological data. Sensors on the AtoN provide this data to the AIS-AtoN Station, which in turn broadcasts this Message 8.

### 2.2.3. MESSAGE 21

Defines the 'Aids to Navigation Report'. AIS-AtoN service enables AtoN providers to broadcast information on the following:

- type of AtoN;
- name of AtoN;
- position of AtoN;
- position accuracy indicator;
- type of position fixing device;
- On/Off position status;
- Real and Virtual AtoN identification;
- dimension of the AtoN and reference positions;
- status of the AtoN systems.

### 2.2.4. MESSAGE 25

Message 25 is a single slot binary message that can for example be used to send encrypted configuration data. See IEC 62320-2 for further details.

### 2.2.5. MESSAGE 26

Message 26 may also be received, processed, and transmitted by an AIS AtoN station. Note that this message is not included in IEC62320-2.

### 2.2.6. MESSAGE PROTOCOLS

There are two types of protocols for sending AtoN AIS messages. They are Fixed Access Time Division Multiple Access (FATDMA) and Random Access Time Division Multiple Access (RATDMA). These two protocols are set to ensure that messages from nearby AIS stations do not conflict.

### 2.2.7. POSITION FIXING DEVICES

For Fixed AtoN, AIS-AtoN unit shall transmit a surveyed position, as configured into the device. The GNSS service will provide tuning and synchronization information only.

The AIS-AtoN unit for use on Floating Aids may use 300KHz band radio beacon DGNSS system to provide a differential corrected for position. It shall indicate the use of DGNSS by setting the position accuracy flag as appropriate.

The use of satellite-based augmentation system (SBAS) is available and the usage of message 17 may be possible in the future.

The unit shall allow user to select position using last read GNSS position algorithm or algorithms in IALA A-126 to calculate off-position.

## 3. PRIMARY CONSIDERATIONS

### 3.1. POWER CONSUMPTION

The power consumption needs to be balanced to the generation facility as well as the power consumption other AtoN such as lights etc. to deliver the required autonomy. The power consumption at the agreed configuration should be measured, rather than rely on the manufacturer's generic data.



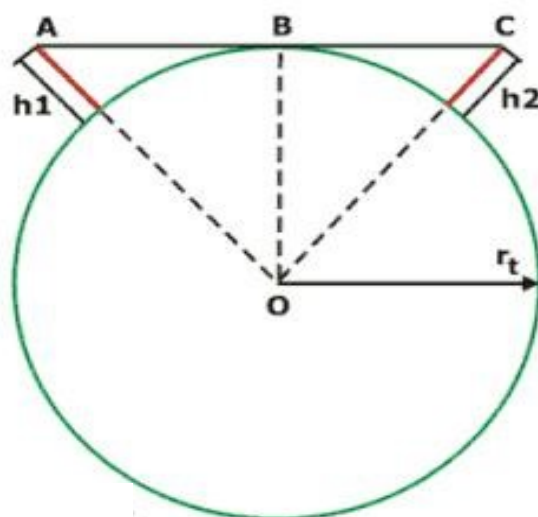
Units configured in RATDMA will consume significantly more power than those configured in FATDMA. The power consumption will also vary depending on the reporting rate and the sleep interval.

See section on Commissioning & Testing for further details. Refer to IALA Guideline 1039 on Designing Solar Power Systems for AtoN.

### 3.2. TRANSMISSION RANGE.

A typical transmission range is between 5 to 15 nautical miles though this will increase with antennas with a higher gain. In areas of very heavy traffic, the volume of AIS transmissions may overload the base station, which will reduce the range that the base station will be able to cover. With Type 1 AIS (FATDMA) in an area of heavy traffic, there may not be enough available slots to be allocated to enable transmission from the AIS-AtoN station.

In a VHF bandwidth operation system, Transmission (Tx) and Reception (Rx) range reach is tightly linked to the height of the antenna. Therefore, location is of key importance, ensuring the highest position in the AtoN for safe installation and maintenance. Figure 1 illustrates the maximum transmission range.



**Figure 1** *Cross-section of the geoids*

$$OA = r_t + h1$$

**Equation 1** Height of antenna with respect to the centre of the earth

Where:

$r_t$  is the Earth's radius

$h1$  is the height of antenna 1 plus height of position against sea level.

$h2$  is the height of antenna 2 plus height of position against sea level.

AB is the distance between the antenna and point of tangent to the earth's surface of the path between antennas.

In this way, the data-reception coverage of an AIS transponder installed on a ship can be calculated as compared to transmission coverage of an AIS transponder installed on a buoy. Knowing the height of the ship's antenna in question, coverage can be estimated by adding the later to the height of the buoy's antenna, as shown in the formula below in nautical miles:

$$Range = 2.55\sqrt{Tx \text{ antenna height (metres)}} + \sqrt{Rx \text{ antenna height (metres)}}$$

## Equation 2    Operational range

In conclusion, the higher the Tx & Rx antenna are placed, the greater the range.

A1 = Height above sea level of antenna installed on the AIS on ship  $\approx$  25 m.

A2 = Height above sea level of antenna of the AIS installed on the buoy.

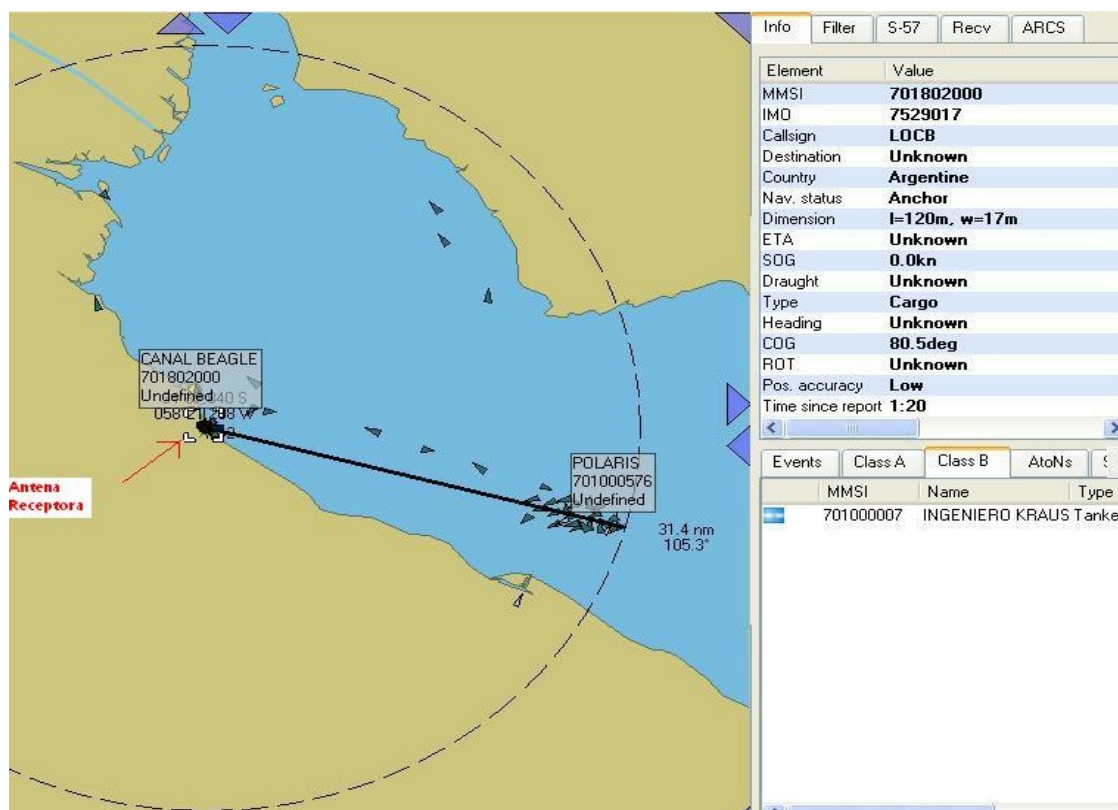
Sample formula to estimate coverage reached by different types of buoys.

- Spar Buoy– Height of AIS-AtoN - A2=10m    Range= 21NM;
- Maritime Buoy-type floating signal – Height of AIS-AtoN - A2=4m    Range= 17NM.

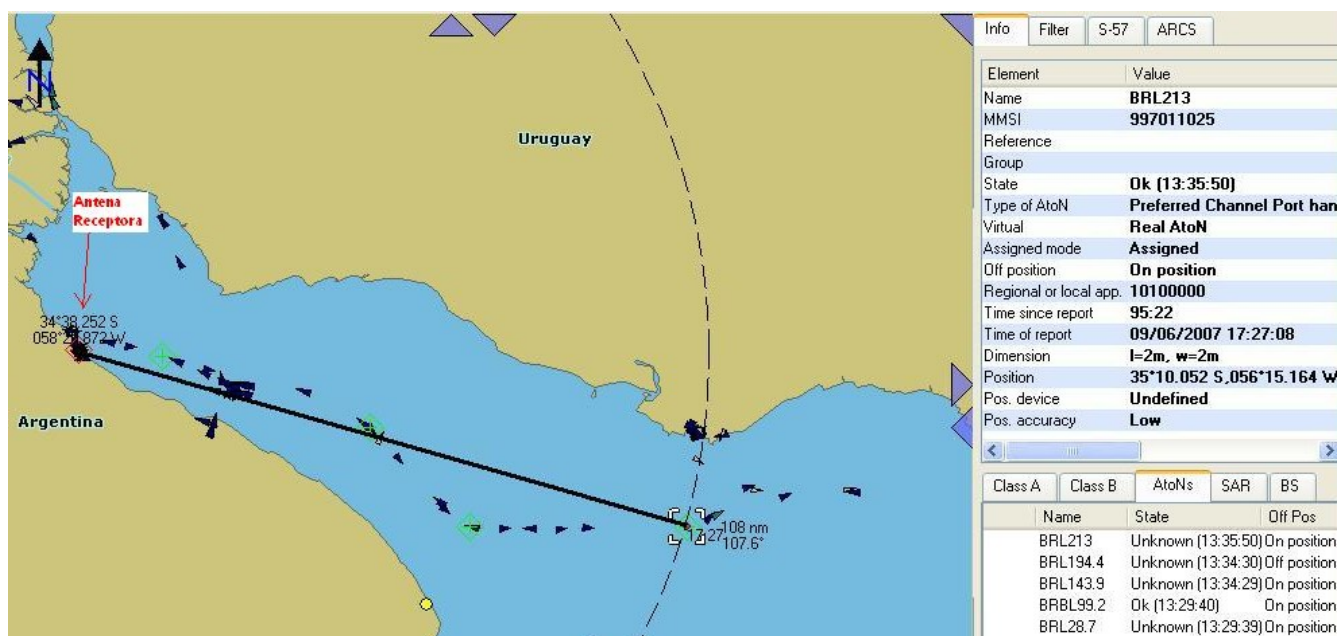
### **3.2.1.    EXTRAORDINARY COVERAGE – DUCTS OR TROPOSPHERIC REFRACTION**

In certain zones, under specific environmental conditions, the troposphere may experience a meteorological phenomenon that creates ducts and channels enabling VHF frequencies to extend across greater distances.

This phenomenon takes place during certain weather conditions during which there are different refractive indices, which force electromagnetic waves to bounce back to the surface, thus broadly enhancing VHF coverage. This phenomenon should not be relied on to provide enhanced coverage.



**Figure 2    Normal situation – Reception coverage  $\approx$  35 km**



**Figure 3** *Situation with ducts – Reception coverage ≈ 200 km*

### 3.2.2. SELECTION OF VHF ANTENNA

The SWR is the ratio between maximum and minimum voltage of the standing wave. It may also be related to reflected and incident power, as shown below:

$$SWR = \frac{D + R}{D - R}$$

#### Equation 3 *Standing Wave Ratio*

Where:

D is the forward amplitude

R is the reflected amplitude

In the case of perfect matching, SWR is 1 and all the power delivered by the system is radiated by the antenna, requiring that all installations endeavour to obtain the lowest possible SWR within the bandwidth or the frequency range in which the antenna operates.

VHF antenna to be installed for AIS applications is required to be marine VHF-type. Generally, they have a central frequency is 156-157 MHz, and a bandwidth of between 6 and 7 MHz, ensuring good performance between 152 and 160MHz, and optimum work (SWR=1) in their central frequency.

Given that the frequency channels used by AIS are 161,975 MHz and 162,025 MHz, it is critical to use an antenna with a broader bandwidth or tuned to a frequency closer to that defined for the work of AIS.

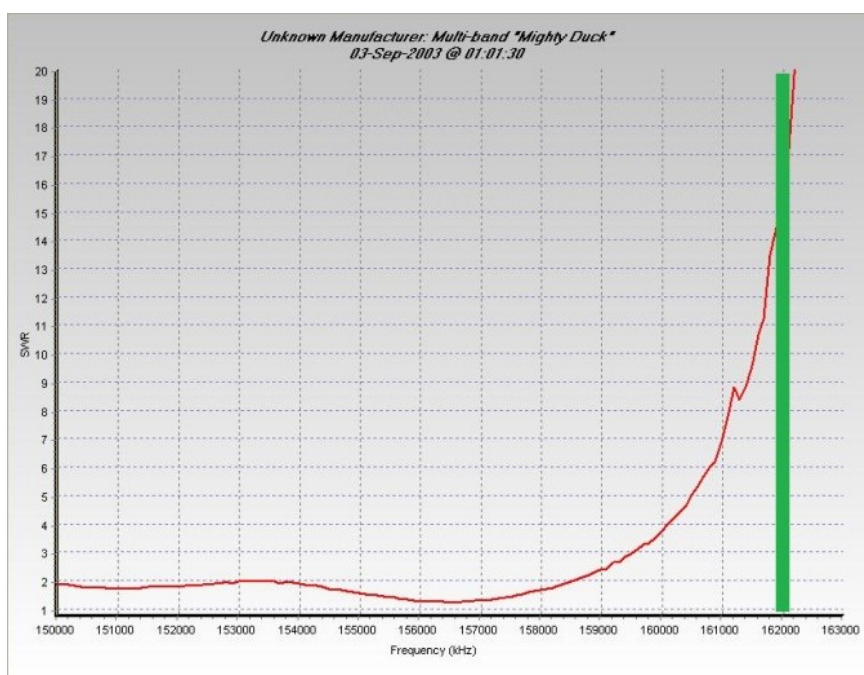
An antenna with a SWR lower than 1.5 is recommended.

### 3.2.3. COMPARISON OF DIFFERENT MARINE ANTENNA

The installation of AIS equipment must be designed around the performance of the antenna, since marine antenna is exposed to metal, dielectric and human influences.

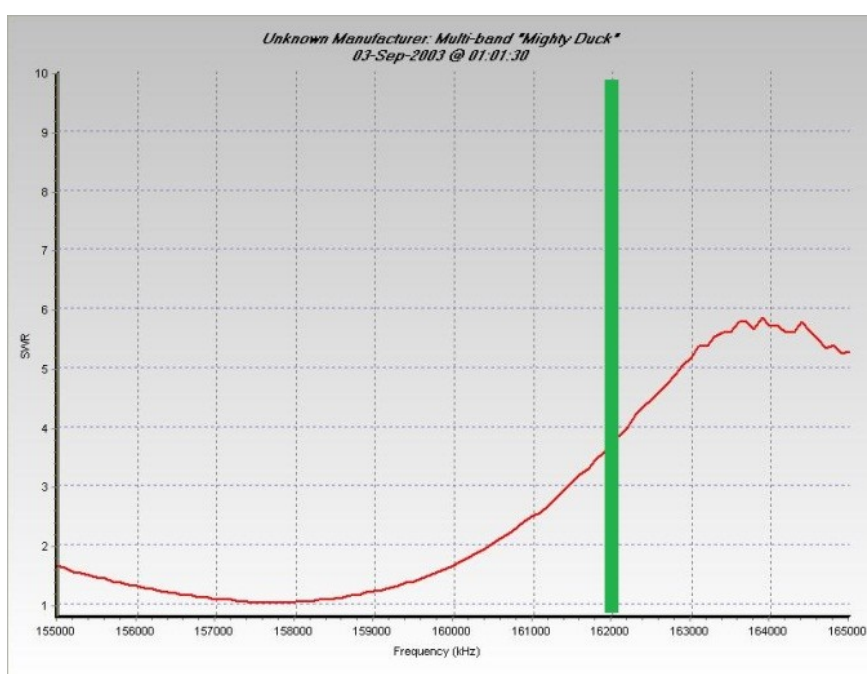
In order to make best choice of antenna to ensure a higher AIS-AtoN efficiency and hence a greater coverage, three trials/measurements of different marine antenna associated to AIS installed on operational buoys are shown below.

As shown in Figure 4, the measured antenna has a very low SWR (SWR around 1 is only achieved between 156 MHz and 157 MHz), though it lacks good response within the AIS frequency of 161,975 MHz and 162,025 MHz where the SWR exceeds 10.

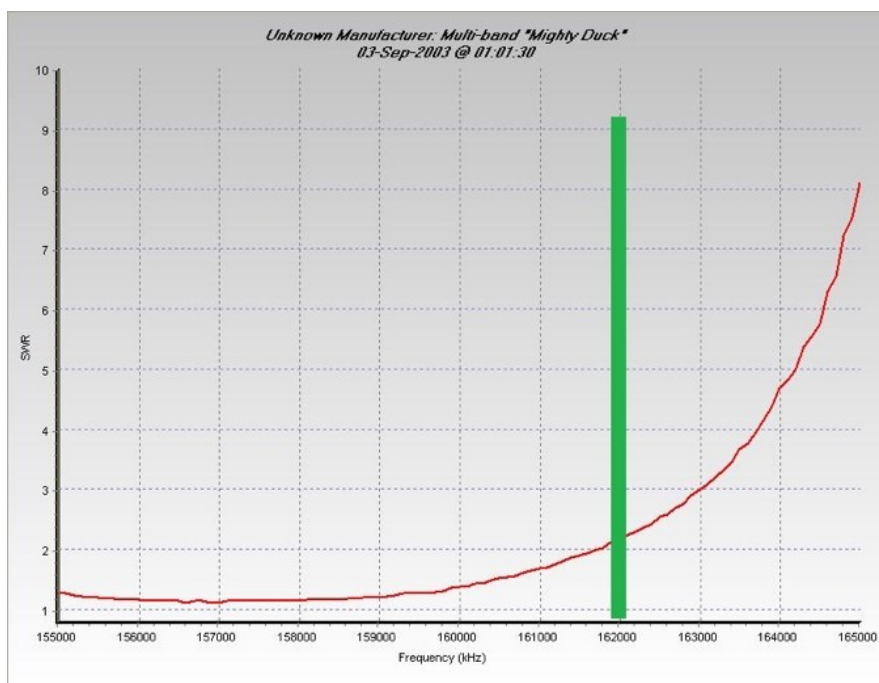


**Figure 4** Measurement 1

In Figure 5, this antenna has obtained better SWR figures for the AIS frequency with an SWR of 4.



**Figure 5** Measurement 2



**Figure 6 Measurement 3**

In Figure 6, it can be seen that this antenna is specially designed for AIS with a broader bandwidth than conventional marine antenna. This allows for a SWR of 2 within the working frequency of AIS, a highly acceptable ratio in terms of installations. Moreover, SWR remains close to 1 between 155 MHz and 159 MHz and gives a much flatter response than the previous ones, showing the high quality of the antenna.

#### 3.2.4. REDUNDANCY

For remote AtoN sites, the user can consider having a system with two AIS-AtoN units. Transmissions alternate between the AIS-AtoN units at the configurable reporting interval.

Should one AIS-AtoN unit fail, the other will continue to transmit at its configured reporting interval: loss of a single AIS-AtoN unit will, in effect double, the reporting interval thus providing redundancy.

### 3.3. INTEGRATED AIS-ATON UNITS

#### 3.3.1. INTEGRATED UNIT WITH OTHER EQUIPMENT

AIS-AtoN can be supplied as an integrated unit with equipment such as lanterns, metrological or hydrological sensors. Monitoring data can include solar voltage, battery voltage, status of operating lamp or flasher, number of available lamps remaining (lamp changer), sun switch status, and flash code.

#### 3.3.2. INTEGRATED WITH LANTERN AND POWER SYSTEM

AIS-AtoN can be supplied complete with an integrated lantern, solar PV power supply with battery storage and all required controls and monitoring facilities.

### 3.4. LICENSING BY LOCAL LICENSING AUTHORITY

The AIS-AtoN may be Real, Synthetic or Virtual (IALA Recommendation A-126), but in every case they must be properly registered with their Maritime Mobile Service Identity (MMSI) accordingly, which must be applied for through the National Authority.

For a user to obtain the MMSI for the first time in their country an interaction with the corresponding agency to define them is usually required. Each country will have its own licensing authority, with particular fees and renewal arrangements that need to be followed.





Reference: IALA Guideline 1084 on the Authorisation of AIS-AtoN

### 3.5. ADDITIONAL SERVICES

---

#### 3.5.1. MESSAGE 8

AIS-AtoN can be used to deliver additional services such as meteorological data and wave data. These can be incorporated into the e-Navigation services infrastructure. Accurate meteorological / hydrological (met/hydro) equipment can be very expensive and will require an analysis of the benefits over the cost of installation. Met/hydro data can be difficult to verify and confirmation of the accuracy of this service needs to be assessed with any consequent liability. A typical navigation buoy may not be suitable for gathering wave data, due to the design not being made for wave following. An assessment of the number of users who are able to receive and display message 8 with met/hydro data needs to be considered otherwise this service will be of little value.

One problem with this AIS capability is that AIS-AtoN units do not always interface easily with met/hydro transducers. Met/hydro transducers with NMEA interface will ease integration with AIS-AtoN.

Different suppliers present alternatives to capture the met/hydro information.

- the AIS-AtoN may receive signals only from compatible sensors;  
This is very inconvenient for already installed met/hydro networks, due to the difficulty of changing sensors.
- the AIS-AtoN may require additional software or a software upgrade;
- the AIS unit may require an interface to be designed and built.

As a general conclusion, it can be said that it is not straightforward to transmit message 8 and that it should not be taken for granted that this will always be possible.

#### 3.5.2. MESSAGE 21 – ATO N STATUS - MONITORING CAPABILITY (BATTERY STATUS, LIGHT STATUS, RACON STATUS, ETC.).

The status bits in Message 21 can also be configured to monitor the status of various conditions of the AtoN.

The setting standards are detailed in Recommendation A-126 and are to be established in the management software / AIS display.

In order to display the condition of items being monitored by the AIS system (e.g. Battery status, Light on/off, Racon on/off) suitable software is required. This software may be offered by either the AIS manufacturer or as a standard AIS tracking package via the internet or bespoke software from a third party.

#### 3.5.3. INTERFACING WITH EXISTING TELEMETRY SYSTEMS

The AIS-AtoN unit may have the capability to interface with a separate telemetry system.

#### 3.5.4. SATELLITE MONITORING OF AIS

It is possible to track AIS and AIS-AtoN in some areas by satellites but this is not fully developed yet.

## 4. PHYSICAL APPLICATION

---

### 4.1. LOCATION OF VHF ANTENNA AND GNSS ANTENNA RECEIVERS.

---

#### 4.1.1. VHF ANTENNA

In the case of floating signals, installing VHF and GNSS antenna at the uppermost section of a superstructure is a disadvantage from the structural point of view, as it is vulnerable to damage if the buoy is struck by a passing ship or when the buoy is being recovered for maintenance.



**Figure 7** *Antenna damage due to collision*

#### **4.1.2. GNSS ANTENNA**

When planning the installation of a GNSS antenna on a buoy, it is a priority that it be clear of any vertical obstruction at all times, considering also the angles of vertical divergence.

It is important to assess the position of satellites for the geographic location. This information is critical to locate the minimum number of satellites in the shortest time possible to assure effective transmission in slot allocation.

The location of the GNSS antenna is of vital importance; poor reception (late acquisition) in FATDMA mode will result in frequent failure of transmission; poor reception (late acquisition) in RATDMA mode will result in increased power consumption and some loss of transmission.

#### **4.1.3. CHOICE OF LOCATION FOR ANTENNAE**

The location of the antennae needs to be carefully considered to optimize radio performance and its vulnerability to damages from collisions or during maintenance activities. The proper choice of antennae (integrated or separate) and the mounting devices selected are all connected to provide optimal long-term performance.

The environmental conditions also affect the choice of equipment and the location of antennas.

### **4.2. IP RATING**

Electronic equipment installed on a Navigation Buoy will be subject to severe environmental exposure.

In order to safeguard the integrity of the equipment, increase its lifespan and ensure its reliability, the installation must prevent the condensation cycle from starting. In order to achieve this, an IP (Ingress Protection) level of not less than IP56 should be specified.

#### **4.2.1. ISSUES**

AIS-AtoN equipment installation is exposed to sudden changes in temperature during the night, which allows water vapour present within the enclosure to condense and produce water drops that rapidly inhibit the protection given by the desiccating agent installed.

As the air gets cooler and releases water drops, the volume of air is reduced giving way to a vacuum inside the enclosure. If the air tightness of the enclosure does not keep humid air from seeping in, the day-night temperature oscillation creates a constant condensation of the water vapour that gets drawn in during the night by the vacuum effect inside the container.

This condensation takes place when the temperature gradient cools a mass of air up to the saturation point, which means that at this temperature a mass of air cannot hold water molecules in gaseous state, therefore releasing them as water drops.

Saturation can only happen given the following three factors:

- temperature gradient (Temperature difference between the air inside and outside the IP box);
- water vapour (The higher the temperature of the air mass, the more water vapour it will carry);
- air flow.

The removal of one of these three factors stops continuous condensation.

To this effect, it is fundamental that water-tightness be preserved, but above all, there should exist a state of balance between exterior and interior pressures eliminating air flow and breaking the cycle that generates condensation.

#### **4.2.2. IP ENCLOSURE RATING**

The enclosures and their connections should, as a minimum, be rated to IP56, although this should be increased to suit local severe environment conditions. The unit should be protected from direct water spray.

For more details see section 8.2

#### **4.2.3. PRESSURE BALANCE**

The pressure in the enclosure needs to be balanced with the outside in order to eliminate air flow between and thus eliminate condensation. This can be achieved with a propriety vapour barrier to the appropriate IP rating. For more details see section 8.2

### **4.3. LIGHTNING PROTECTION.**

In areas where Lightning strikes are considered to be a specific hazard, consideration should be given to protecting the AIS-AtoN unit from this by installing Surge Protection.

The implementation of a surge protection to guard the equipment against an atmospheric discharge is essential in any installation of electronic equipment afloat.

These atmospheric discharges affect the stability of the equipment for the operation in the GNSS signal acquisition and VHF transmission.

Lightning protection can take the form of diode-based surge protectors, varistors, gas discharge units and good grounding.

Reference: IALA Guideline 1012 – Protection of Lighthouses and AtoN against damage from lighting.

#### **4.3.1. GROUNDING**

Good equipotential bonding between the superstructure, mounted equipment and the sea water will provide some protection against the raised electrical potential during a lightening storm. This will also prevent a static build up on the buoy.

## **5. COMMISSIONING & TESTING**

### **5.1. CONFIGURATION**

AIS-AtoN units require programming for the following parameters as a minimum:

- 1 MMSI.
- 2 Name and type of Navigation Aid.



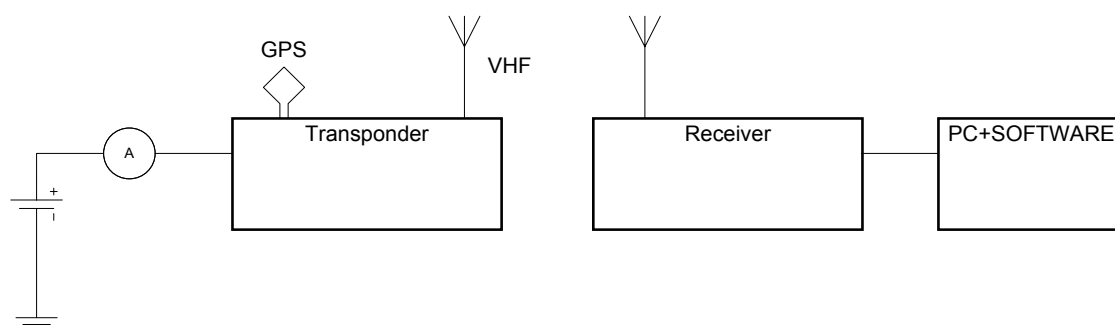
- 3 AIS type (Type1, 2 or 3).
- 4 Charted position.
- 5 Guard ring (off-position alarm).
- 6 For type 1: Transmission interval, Slot allocation.
- 7 AIS type (Real, Virtual or Synthetic).
- 8 Dimensions of the AtoN.

Confirmation of all on site programmed information needs to be recorded with the Competent Authority.

It is recommended that the user confirm the performance of the AIS-AtoN unit prior to deployment by carrying-out the following tests. The frequency of the sample period and the duration of the satellite sample can be adjusted by the user for specific locations & site conditions.

## 5.2. FUNCTIONAL TESTS

This is an example of a test for a Type 1 transmission measuring voltage, current and power consumption from the power supply. It also gauges the transmit power on both AIS-AtoN systems at different operating conditions.



A= Ampere meter

**Figure 8** *Basic connection between systems for Type 1*

### 5.2.1. EQUIPMENT

AIS-AtoN with GNSS antenna, connected to a VHF antenna set at AIS 1 161.975 MHz and AIS 2 162.025 MHz frequency.

### 5.2.2. MEASURING INSTRUMENTS

- Power supply;
- Multimeter with recording function;
- Attenuator;
- Spectrum analyzer;
- VHF receiver;
- Storage oscilloscope;
- SWR Meter.

### 5.2.3. Testing methodology – message 21

#### 5.2.3.1. Regular operation

Test should be conducted on both systems and verify that  $SWR \leq 1.5$ .

Measure transmission power, voltage, current and peak/standby power consumed.

**5.2.3.2.** Same conditions without GNSS signal.

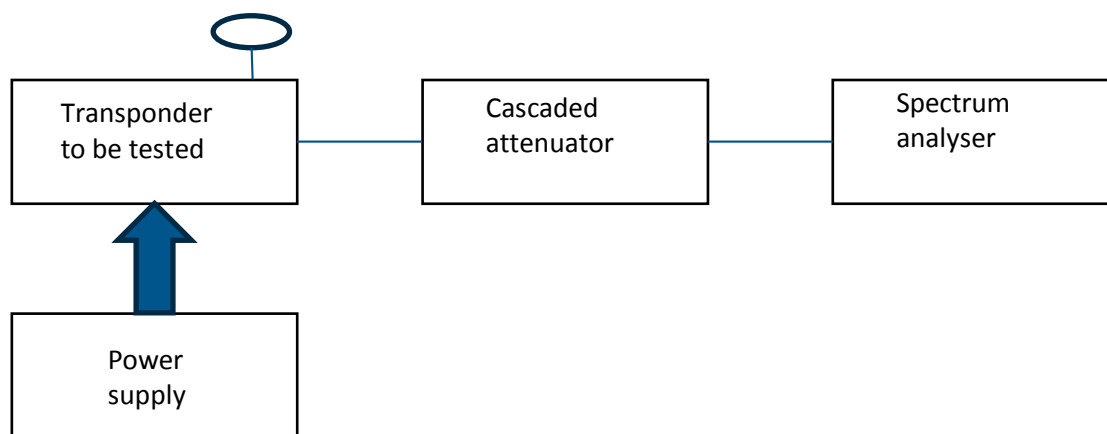
During normal operation, block out GNSS reception to keep the equipment from transmitting and being detected. Measure the following: Voltage, current and peak/standby power consumed.

**5.2.3.3.** Operation with varying power supply.

Within a transmission cycle period for each voltage step change, determine equipment operating performance by varying power supply at 500 mV throughout the specified voltage range. Measure consumption peak and standby power as well as transmit power during this test.

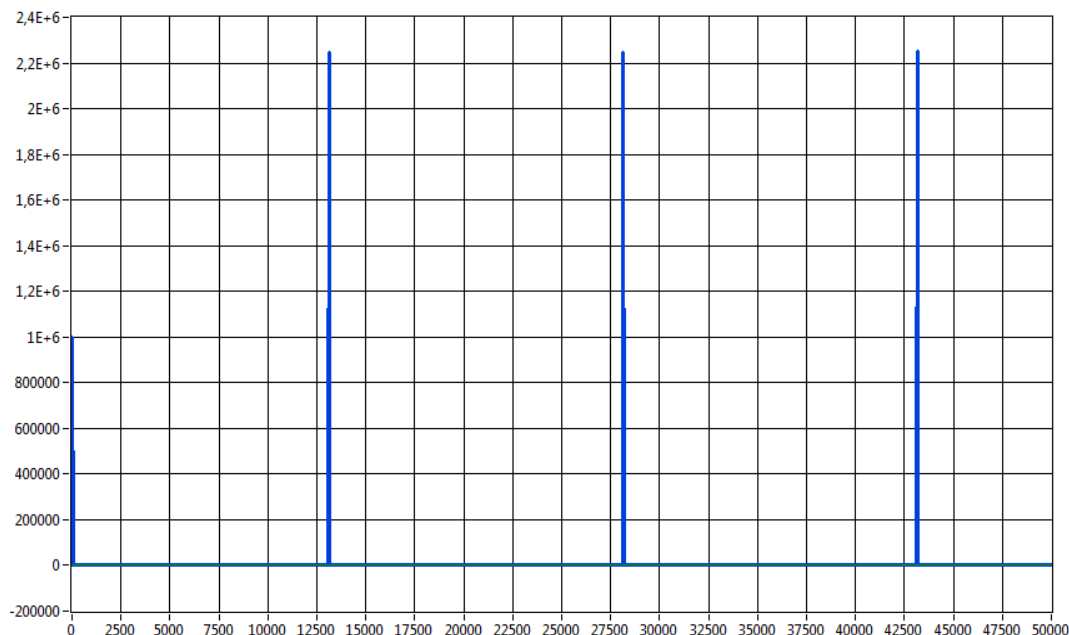
**5.2.4.** Transmit power measurement

In order to characterize the output power and the associated spectrum, connect a cable from the VHF outlet of the equipment directly to a spectrum analyser inserting suitable attenuators to protect the analyser according to its specifications.



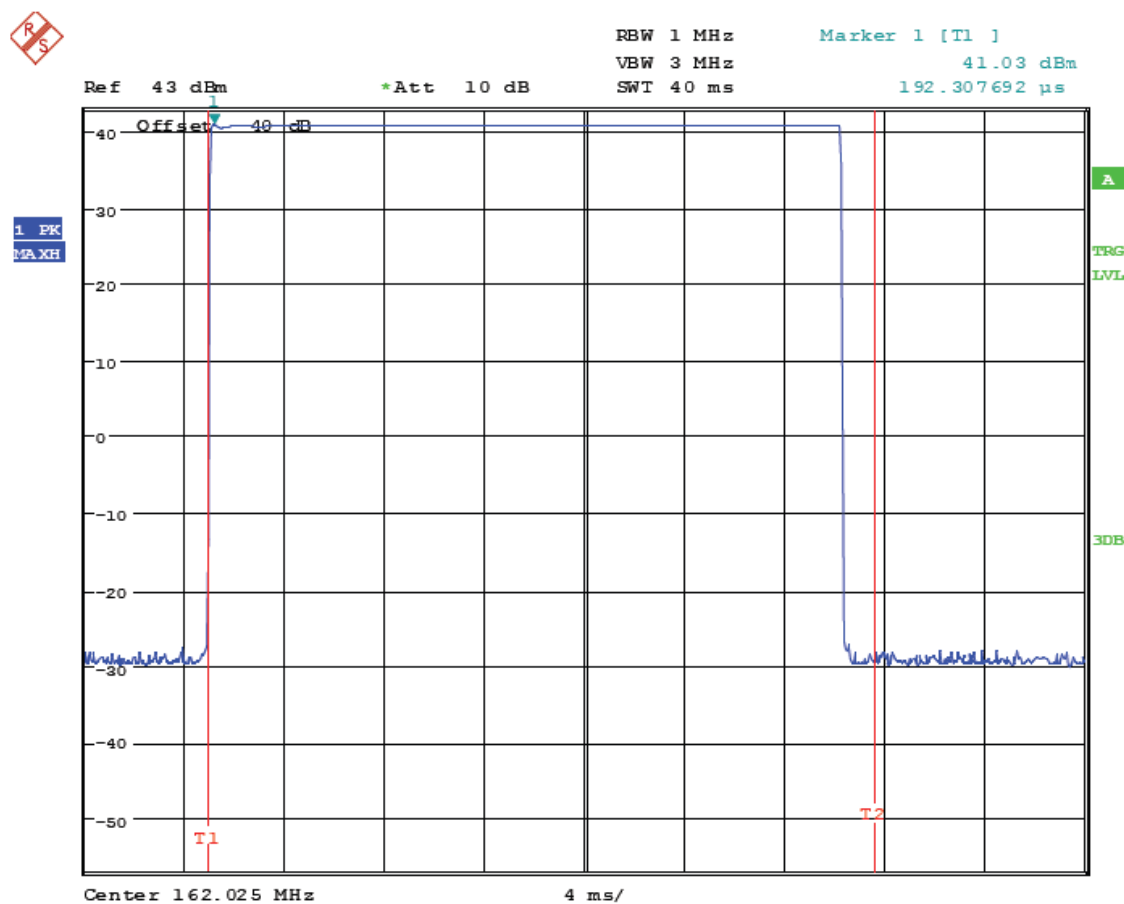
**Figure 9** Measurement of power transmitted via direct connection through cable and signal attenuation.

**5.2.5.** DATA, CURVES, IMAGES AND GRAPHS - EXAMPLE.



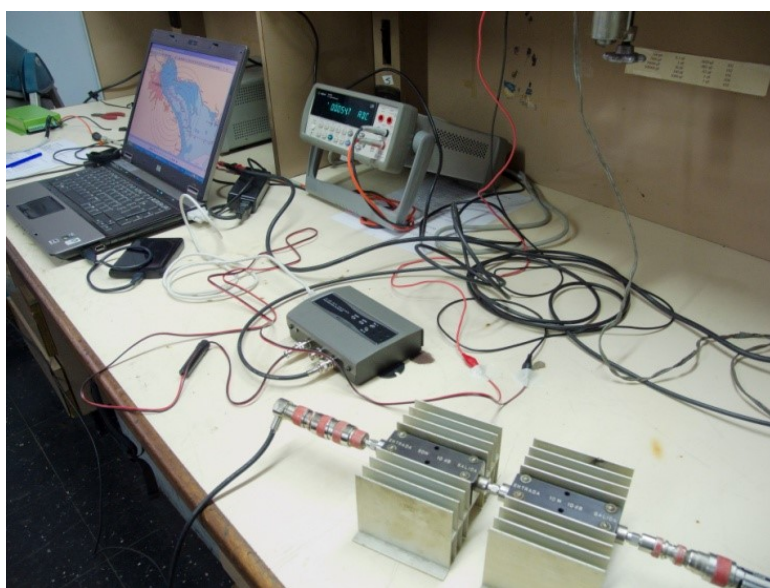
**Figure 10** Consumption [µA] vs. Samples, samples taken every 12 ms.

This shows the peak current used during transmission every three minutes.



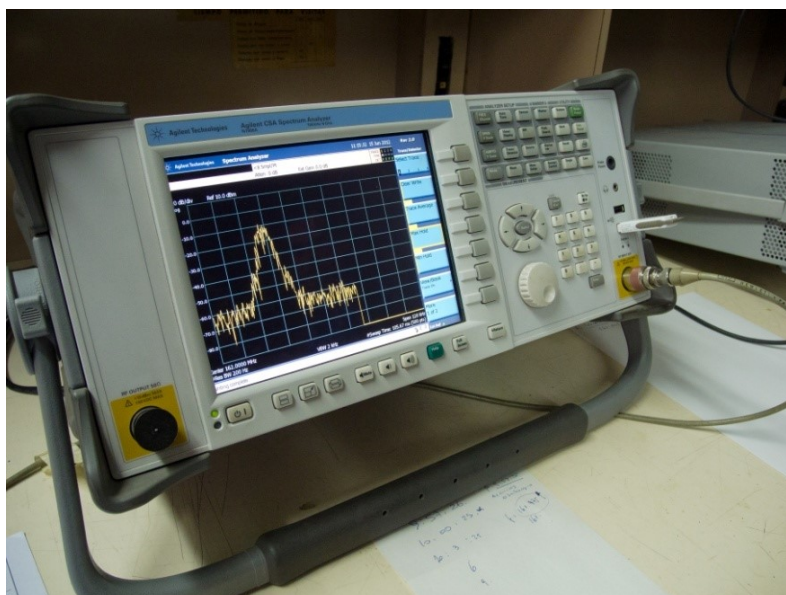
**Figure 11** Consumption during transmission [A]

This is an expanded view of the transmission shown in Figure 10.

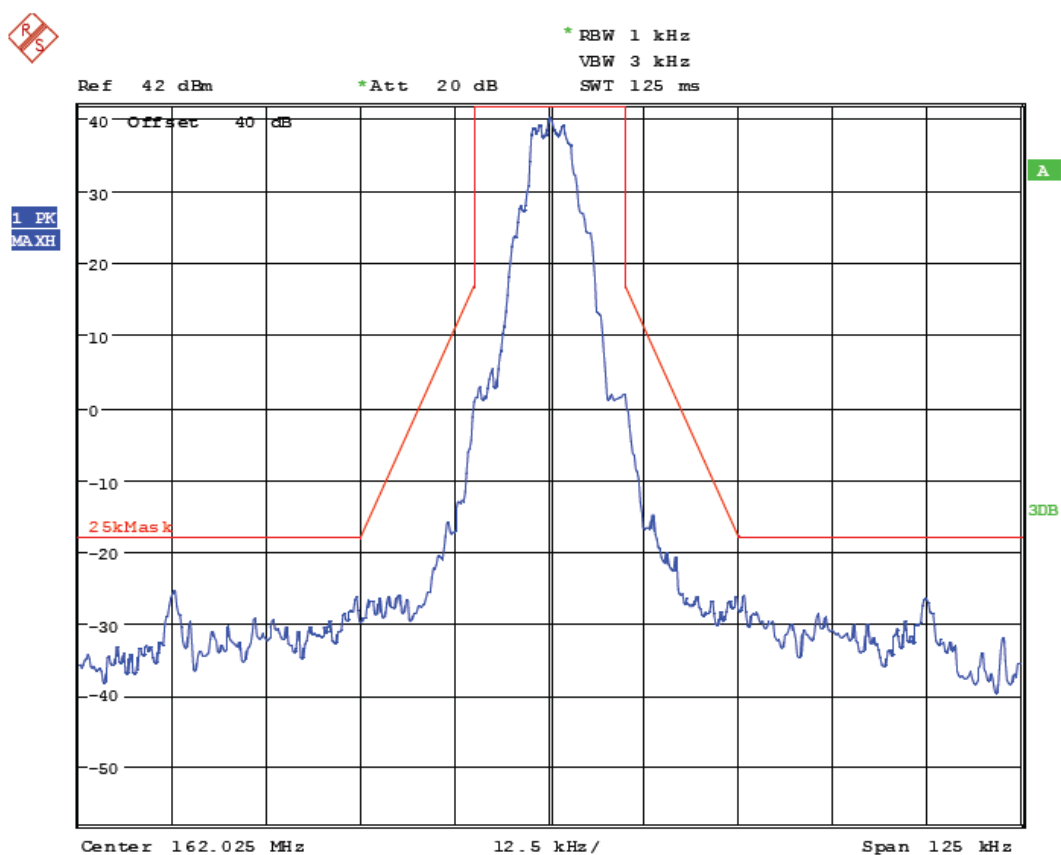


**Figure 12** Bench test

AIS Transponder receiver connected to a notebook computer via RS-232, Multimeter for measuring and cascaded attenuators for the transmitted signal to be displayed on the Spectrum.



**Figure 13** *Spectrum analyzer displaying transmission spectrum.*



**Figure 14** *Trace from spectrum analyser showing transmission frequency 162.025 MHz of the AIS-AtoN output.*

### 5.2.6. PRE-DEPLOYMENT TRIAL

Prior to deployment, the AIS-AtoN should be set-up for transmission at an approved location and its performance monitored remotely. Testing of off-station alarm should also be part of the testing sequence by moving it beyond its guard ring.

When testing the AIS-AtoN that is not in its assigned position, agreement must be gained with the licensing authority to avoid confusion to local shipping. If two AIS-AtoN use the same MMSI this will cause confusion; consideration should be given to using a specific MMSI for test purposes only.

### 5.2.7. ANALYSIS OF RESULTS

It is recommended to compare the results of the tests with the manufacturer's specifications for compliance.

### 5.2.8. TESTS PRE DEPLOYMENT

- Power Consumption;
- Output Power;
- SWR;
- Slot synchronization (if possible);
- Functional test;
- Off-stations alarms;
- Configuration.

### 5.2.9. TESTS POST DEPLOYMENT

- Functional test;
- Transmitted position;
- Configuration;
- Range test.

## 6. MAINTENANCE & OPERATION

### 6.1. MAINTENANCE REQUIREMENTS

Maintenance and implementation of AIS-AtoN equipment may vary depending on the following aspects:

- Characteristics of the device;
- Implementation environment: fluvial (inland waters) or maritime;
- Types of aids to navigation;
- Environmental conditions.

Considering these differences, it must be noted that when the equipment has been integrated by the supplier there is a lower risk of failure to the internal connections, external antenna connection, balance of energy, etc. User-implemented AIS equipment runs a higher risk of failing.

The purpose of this guideline is to consider the probability of failures occurring due to human error, requiring that the process be standardized to minimize risk of failure.

#### 6.1.1. TECHNICAL STAFF

One of the most common situations to be faced on board the buoy tender while conducting Maintenance and Repair tasks is that of repetitive work. It is essential to maintain attention to detail when maintaining and

programming AIS-AtoN as this is the most common point of failure. Verification of the received signal post installation and repair is essential to confirm the correct operation of the unit.

Close attention to the watertight integrity of glands and connectors is also essential.

Technical staff are responsible for verifying:

- AIS-AtoN operation;
- VHF and GNSS antenna cables;
- Non-intrusive inspection of the condition of VHF antenna, of its flexibility and of the GNSS antenna if placed on the outside;
- Condition of wiring and connectors, stiffness, cracks, moisture and oxidation;
- SWR measurement (if possible);
- Power supply checking;
- Fixing system;
- Transmission range and coverage measurement.

It is essential that technical staff in charge of AIS-AtoN maintenance be properly trained in applied techniques and best practices. Since AIS-AtoN maintenance and implementation on navigational aids is not a routine task, their performance is to be assessed and monitored periodically.

### **6.1.2. CONFIGURATION SOFTWARE**

The technician needs to be well acquainted with the configuration software; poor programming is a very common problem in this area.

Over time, equipment will change and traceability of existing versions will lower the likelihood of confusing software configuration of AIS-AtoN equipment. Good configuration management methodology should be in place to ensure accurate tracking of configuration of the AIS-AtoN and the embedded software version.

## **6.2. TRAINING**

### **6.2.1. CAPABILITIES REQUIRED FOR MAINTAINERS**

The technical staff associated with the maintenance and operation of AIS-AtoN should have specific training to enable them to work safely and competently on the AIS-AtoN. The skills required to maintain and programme AIS-AtoN units at sea are at a higher level than that required to maintain a basic lighted buoy.

### **6.2.2. HUMAN, PHYSICAL AND TECHNICAL RESTRICTIONS ON BOARD.**

When a vessel gives support to an AIS-AtoN, technical personnel on board do not usually have the best working conditions, therefore for operational reasons the AIS-AtoN equipment installation needs to be conducted by specially trained personnel or in workshops designed for such purposes.

### **6.2.3. TRAINING DOCUMENTATION**

As with all training, manuals need to be plain, concise, reader-friendly and readily available to the maintainer.

## **6.3. SPARE TRANSPONDERS**

It is necessary to have spare transponders to replace those that fail, are damaged by passing ships, vandalized or out of service, re supply time and for any other reason. The best way to maintain the service is to replace a malfunctioning transponder and to repair at the workshop.

The spare number of transponder required depends on the installed number. The rate of spares needs to be evaluated and adapted by each authority.

**Table 2 Suggested spare transponder holding**

Installed number of transponders	Suggested number of spare transponders
1 to 3	1
4 to 6	2
7 to 16	3
17 to 50	20 %

## 7. SELECTION OF EQUIPMENT

When selecting a suitable AIS-AtoN system, the following points should be considered:

- Life cycle cost analysis;
- Reliability;
- Size of unit compared to available space;
- Simplicity to configure and interrogate;
- Upgrade easy to perform;
- After-sales service and support;
- Hardware and software capacity expansion;
- Different hardware solutions adaptable to the equipment base;
- Ease of installation;
- External connection (Example: high-integrity external connections.);
- Low power consumption.

## 8. GENERAL CONSIDERATIONS FOR INTEGRATING AN AIS-AtoN SYSTEM

The best way to deliver a reliable installation of an AIS-AtoN whether integrated or not, is to ensure the highest quality of components, processes and people involved; moreover, to provide appropriate training for all the qualified personnel in charge at every stage of the deployment.

If the equipment is not fully integrated when delivered by the supplier, such work must be carried out by the installer, making use of watertight enclosures that ensure the durability of the AIS-AtoN equipment.

The following sections offer guidelines for a high standard of assembly for the watertight enclosures and connections and to establish good installation procedures intended to ensure quality assembly and efficiency in the use of materials and resources to avoid common errors.

### 8.1. IMPACT ON BUOY PERFORMANCE

The installation of AIS-AtoN on buoys may impair the buoyancy and stability characteristics. The overall mass and centre of gravity of any additional items needs to be considered at the design stage.

The AIS-AtoN unit requires a GNSS receiver and VHF antenna at high level, this may require cables to pass the light unit and affect lantern performance. All cable routes need to be considered at the design stage to minimise this.



## 8.2. GENERAL ASSEMBLY

Approved and tested assemblies ensure enclosures capable of withstanding challenging weather conditions, thereby preserving the equipment within.

In a harsh environment, the use of two enclosures (> IP56) may be considered to provide the required level of protection.

It is recommended that the VHF and GNSS antenna be installed at the final stage of assembly. UV stabilized cables should also be used.

### 8.2.1. HARD WIRED AND PLUG CONNECTORS

Plugs and connectors offer flexibility in maintenance and assembly but are a weak point for moisture ingress and can be a common failure mode.



*Figure 15 Example of a double enclosure*

### 8.2.2. PREPARATION OF INLETS IN WATERTIGHT ENCLOSURES

Ensuring a completely watertight enclosure is a challenging task given that the holes on the sides to let the cables in and to place cable glands or connectors are not original factory conditions. Therefore, any holes must be drilled to the correct diameter for the gland. IP rated glands and connectors to suit the environment must be selected.

It is critical to seal all joints between the inlets and the corresponding cable glands and connectors using flexible glue so as to accompany the deformation derived from temperature oscillations.

In accordance with the installation guidelines, antenna must be plugged onto the same side in all boxes; likewise, power supply cables and earthing onto a different side.





**Figure 16** *Different sides of the perforated box*

### 8.2.3. ASSEMBLY OF CABLE GLANDS

Cable glands and / or connectors must be fitted carefully so that both the inner and outer rubber washers of the box do not get blocked and deteriorated when screwing the inner nut, making sure in this way that the whole set is firmly attached to the sides.

The clearance between glands and cables must be as insignificant as possible to reduce moisture ingress.

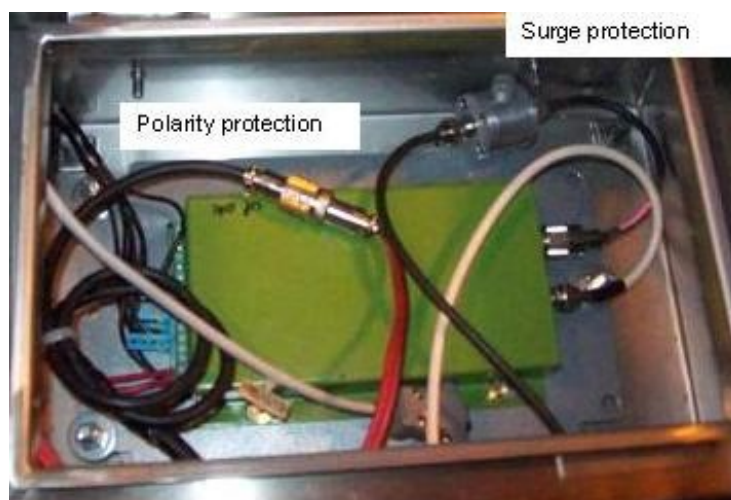
A selection of different consecutive diameters may be necessary since there is no heat shrink tubing that will simultaneously adjust both gland and coaxial cable.

### 8.2.4. PREPARATION OF THE AIS SYSTEM

Integrating different electronic devices requires that equipment and connections be correctly fitted and secure for all cables, thereby avoiding failure due to poor contact, loss of data and functional efficiency and the possible ensuing breakdown of the equipment.

Inserting a rubber plate in the mounting system of the AIS equipment has proven to be an effective way of softening vibration during the operation.

In some non-integrated installations it is recommended to fit a polarity protection device in the enclosure between the power supply system and the input of the equipment.



### Figure 17 Equipment with its protection

#### 8.2.5. Sealing of external connections

If the installation is performed using glands or connectors, moisture is liable to seep in, requiring the use of heat shrink tubing. This component that protects the cable connection to the external box can be easily fitted; otherwise it can be filled with a paste that will seal the clearance between the heat shrink and the cable.

Once the stretch of heat shrink to be applied has been determined, the position of the cables must be calculated before the final adjustments are made.

When the heat shrinks have been properly fitted, the cables must protrude downwards -as shown in Figure 18 to enable smooth outpour of water.

As an alternative to shrink tube, it is possible to use self-amalgamating tape which provides an effective seal and can be replaced on site.



Figure 18 Sealing of antenna and power supply inputs.



Figure 19 Sealed cable gland with heat shrink

#### 8.2.6. CONNECTIONS AND COMPLETION

The gas surge protection device must be inserted in the input of the VHF antenna immediately inside the internal watertight box keeping the connections isolated from any source of moisture.



Finally, VHF and GNSS antenna must be connected, verifying the SWR of the former, as described in section 3.2.3.

### 8.3. GENERAL OUTLINES FOR THE ASSEMBLY

---

- 1 Follow the Checklist at Annex A.
- 2 The necessary components must be recorded on the Checklist.
- 3 The power supply system must always be checked.
- 4 Enclosures must be assembled to enable access to the power supply connections and the VHF/GNSS antenna. It is important that this process be recorded in the Checklist so as to keep track of intermediate controls.
- 5 If an external enclosure has been fitted, this must be recorded in the Checklist.
- 6 When antenna cables have been fitted, the SWR of the VHF antenna must be measured and the water tightness of the cable glands must be visually verified and recorded in the Checklist.
- 7 Having completed the installation, it is recommended to test the system for at least one week prior to deployment.

## 9. ACRONYMS

---

AIS	Automatic Identification System
AIS-AtoN	AIS-Aid to Navigation transponder
AtoN	Aid(s) to Navigation
Circ.	Circular (IMO)
D	Forward amplitude
DGNSS	Differential Global Navigation Satellite System
FATDMA	Fixed Access Time Division Multiple Access
GNSS	Global Navigation Satellite System
GPS	Global Positioning System
IEC	International Electrotechnical Commission
IMO	International Maritime Organisation
IP	Ingress Protection
ITU	International Communications Union
kHz	Kilohertz
MHz	Megahertz
MMSI	Maritime Mobile Service Identity
ms	milliseconds
NMEA	National Marine Electronics Association
PC	Personal Computer
R	Reflected amplitude
RATDMA	Random Access Time Division Multiple Access
Rx	Receiver
SBAS	Satellite Based Augmentation System



SN	Safety of Navigation (IMO)
SOTDMA	Self-Organising Time Division Multiple Access
SWR	Standing Wave Ratio
Tx	Transmitter
UV	Ultra Violet (light)
VDL	VHF Data Link
VHF	Very High Frequency
μA	microampere

## 10. REFERENCES

---

- [1] IALA Recommendation A-126 Edition
- [2] IEC 62320-2 – AIS AtoN Stations Operational and Performance Requirements, methods of testing and required test results
- [3] ITU-R M.1371-4 – Technical characteristics for an automatic identification system using time-division multiple access in the VHF maritime mobile band
- [4] IALA Guideline 1012 – Lightning Protection
- [5] IALA Guideline 1039 on Designing Solar Power Systems for AtoN
- [6] IALA Guideline 1084 Authorisation of AIS-AtoN.

## ANNEX A    SAMPLE CHECKLIST

***Table 3*** ***Sample checklist***

Checklist for the verification of AIS-AtoN installation		
<b>Name of the station</b>	Dover East	
<b>MMSI</b>	99MIDxxxx	
<b>Person at workshop</b>	John Doe	
<b>Person on board</b>	EzmiSahrani	
<b>Item</b>	<b>Description</b>	<b>Signature</b>
Type of AtoN	20 (North Cardinal) (Ref. A-126, table 1)	
AIS serial number	123456	
Enclosure	Make, model and quantity	
Connectors	Make, model and quantity	
VHF Antenna	Make, model and quantity	
GNSS Antenna	Make, model and quantity	
Surge Protection	Make, model and quantity	
Heat shrink tubes or other protection	Heath shrink or self-amalgamating type	
Cable specification	Make and model	
Equipment testing time	7 days	
Antenna SWR	1.5	
Photography	Attached	
Configuration Check	OK	
Post deployment functional test	Passed	
Date	2012-10-11	